

6000XL & 6100XL Series Reach Ins

Original Instructions Installation, Operation and Maintenance Manual

This manual is updated as new information and models are released. Visit our website for the latest manual.



Safety Notices

⚠ Warning

Read this manual thoroughly before operating, installing or performing maintenance on the equipment. Failure to follow instructions in this manual can cause property damage, injury or death.

⚠ DANGER

Do not install or operate equipment that has been misused, abused, neglected, damaged, or altered/modified from that of original manufactured specifications.

⚠ DANGER

Keep power cord AWAY from HEATED surfaces. DO NOT immerse power cord or plug in water. DO NOT let power cord hang over edge of table or counter.

⚠ DANGER

All utility connections and fixtures must be maintained in accordance with Local and national codes.

⚠ Warning

Authorized Service Representatives are obligated to follow industry standard safety procedures, including, but not limited to, local/national regulations for disconnection / lock out / tag out procedures for all utilities including electric, gas, water and steam.

⚠ Warning

Do not store or use gasoline or other flammable vapors or liquids in the vicinity of this or any other appliance. Never use flammable oil soaked cloths or combustible cleaning solutions, for cleaning.

⚠ Warning

This product contains chemicals known to the State of California to cause cancer and/or birth defects or other reproductive harm. Operation, installation, and servicing of this product could expose you to airborne particles of glasswool or ceramic fibers, crystalline silica, and/or carbon monoxide. Inhalation of airborne particles of glasswool or ceramic fibers is known to the State of California to cause cancer. Inhalation of carbon monoxide is known to the State of California to cause birth defects or other reproductive harm.

⚠ Warning

Do not use electrical appliances or accessories other than those supplied by the manufacturer.

⚠ Warning

Use caution when handling metal surface edges of all equipment.

⚠ Warning

This appliance is not intended for use by persons (including children) with reduced physical, sensory or mental capabilities, or lack of experience and knowledge, unless they have been given supervision concerning use of the appliance by a person responsible for their safety. Do not allow children to play with this appliance.

⚠ Caution

Use caution handling, moving and use of the R290 refrigerators to avoid either damaging the refrigerant tubing or increasing the risk of a leak. Components shall be replaced with like components. Servicing shall be done by a factory authorized service personnel to minimize the risk of possible ignition due to incorrect parts or improper service.

Notice

Proper installation, care and maintenance are essential for maximum performance and trouble-free operation of your equipment. Visit our website www.mtwkitchencare.com for manual updates, translations, or contact information for service agents in your area.

Notice

This product utilizes Ecomate blowing agent methyl formate

Table of Contents

Section 1

General Information

Model Numbers	5
Serial Number Information	5
Warranty Information	5
Regulatory Certifications	5

Section 2

Installation

Location	7
Weight of Equipment	8
Clearance Requirements.....	8
Drain Connections.....	8
Dimensions	9
Electrical Service	10
Energy Star	11
Refrigeration	11
Leveling.....	11
Stabilizing.....	11
Leg & Caster Installation.....	12
Door Reversal Procedure	12

Section 3

Operation

R290 Controls/Programming/Settings.....	15
Refrigerator Settings.....	15
Refrigerator Defrost.....	15
Freezer Settings	16
Freezer Defrost	16
R290 Temperature Control & Display	17
R290 Evaporator Fan Operation.....	17
R290 Changing Display from Fahrenheit to Celsius on ERC112 Control.....	18

Section 4

Maintenance

Cleaning and Sanitizing Procedures.....	19
General.....	19
Interior Cleaning.....	20
Exterior Cleaning.....	20
Drain.....	21
Cleaning the Condenser Coil	21
Casters.....	21
Doors/Hinges.....	21
Preventing Blower Coil Corrosion	21

Section 5

Wiring and Parts

Wiring Diagrams.....	22
Parts	23

THIS PAGE INTENTIONALLY LEFT BLANK

Section 1

General Information

Model Numbers

This manual covers the following models:

Refrigerators	
Single Section	Two Section
6025XL-S(H)	6051XL-S(H)
6025XL-G(H)	6051XL-G(H)

Freezers	
Single Section	Two Section
6125XL-S(H)	6151XL-S(H)

- H designation signals half door models
- S designation signals stainless door models
- G designation signals glass door models

Serial Number Information

The serial number is on the identification plate that also includes the model number. The identification plate is located inside the cabinet on the left interior wall.

Always have the serial number of your unit available when calling for parts or service.

Warranty Information



Visit

<http://www.delfield.com/warranty> to:

- Register your product for warranty.
- Verify warranty information.
- View and download a copy of your warranty.

Regulatory Certifications

Models are certified by:

-  National Sanitation Foundation (NSF)
-  Underwriters Laboratories (UL)
-  Underwriters Laboratories of Canada (cUL)

THIS PAGE INTENTIONALLY LEFT BLANK

Section 2 Installation

⚠ DANGER

Installation must comply with all applicable fire and health codes in your jurisdiction.

⚠ DANGER

Use appropriate safety equipment during installation and servicing.

⚠ Warning

Do not damage the refrigeration circuit when installing, maintaining or servicing the unit.

Location

⚠ Warning

This equipment must be positioned so that the plug is accessible unless other means for disconnection from the power supply (e.g., circuit breaker or disconnect switch) is provided.

⚠ Warning

Adequate means must be provided to limit the movement of this appliance without depending on or transmitting stress to the electrical conduit or gas lines.

⚠ Warning

To avoid instability the installation area must be capable of supporting the combined weight of the equipment and product. Additionally the equipment must be level side to side and front to back.

⚠ Warning

This equipment is intended for indoor use only. Do not install or operate this equipment in outdoor areas.

The location selected for the equipment must meet the following criteria. If any of these criteria are not met, select another location.

- The location **MUST** be level, stable and capable of supporting the weight of the equipment.
- The location **MUST** be free from and clear of combustible materials.
- Equipment **MUST** be level both front to back and side to side.
- Position the equipment so it will not tip or slide.
- Front casters **MUST** be locked once positioned.
- Recommended air temperature is 60° - 100°F (16° - 38°C).
- Proper air supply for ventilation is **REQUIRED AND CRITICAL** for safe and efficient operation. Refer to Clearance Requirements chart on page 8.
- Do not obstruct the flow of ventilation air. Make sure the air vents of the equipment are not blocked.
- Do not install the equipment directly over a drain. Steam rising up out of the drain will adversely affect operation, air circulation, and damage electrical / electronic components.

Weight of Equipment

Description	Models	Weight
1 Section Refrigerators		
Solid Doors	6025XL-S(H)	274 lbs (124 kg)
Glass Doors	6025XL-G(H)	338lbs (153kg)
2 Section Refrigerators		
Solid Doors	6051XL-S(H)	454 lbs (206 kg)
Glass Doors	6051XL-G(H)	548 lbs (249 kg)
1 Section Freezers		
Solid Doors	6125XL-S(H)	274 lbs (124 kg)
2 Section Freezers		
Solid Doors	6151XL-S(H)	454 lbs (206 kg)

Clearance Requirements

⚠ DANGER

Minimum clearance requirements are the same for noncombustible locations as for combustible locations. The flooring under the appliance must be made of a noncombustible material.

⚠ DANGER

Risk of fire/shock. All minimum clearances must be maintained. Do not obstruct vents or openings.

Top	
6025XL-S(H) & 6051XL-S(H)	12.00" (30cm)
6025XL-G(H) & 6051XL-G(H)	12.00" (30cm)
6125XL-S(H) & 6151XL-S(H)	20.00" (50cm)

- Keep the vents clean and free of obstruction.
- Casters or optional legs must be used and not removed.

Drain Connections

⚠ Warning

Moisture collecting from improper drainage can create a slippery surface on the floor and a hazard to employees. It is the owner's responsibility to provide a container or outlet for drainage.

Dimensions

Model	Length	Depth	Height
1 Section Refrigerators			
6025XL-S(H)	25.5" (65cm)	32.38" (82cm)	79.62" (202cm)
6025XL-G(H)			
2 Section Refrigerators			
6051XL-S(H)	51" (139cm)	32.38" (82cm)	79.62" (202cm)
6051XL-G(H)			
1 Section Freezers			
6125XL-S(H)	25.5" (65cm)	32.38" (82cm)	79.62" (202cm)
2 Section Freezers			
6151XL-S(H)	51" (139cm)	32.38" (82cm)	79.62" (202cm)

Model	Volume
1 Section Refrigerators	
6025XL-S(H)	20ft ³ (595L)
6025XL-G(H)	
2 Section Refrigerators	
6051XL-S(H)	43.5ft ³ (1303L)
6051XL-G(H)	
1 Section Freezers	
6125XL-S(H)	20ft ³ (595L)
2 Section Freezers	
6151XL-S(H)	43.5ft ³ (1303L)

Electrical Service

⚠ DANGER

Check all wiring connections, including factory terminals, before operation. Connections can become loose during shipment and installation.

⚠ Warning

This appliance must be grounded and all field wiring must conform to all applicable local and national codes. Refer to rating plate for proper voltage. It is the responsibility of the end user to provide the disconnect means to satisfy the authority having jurisdiction.

- Plug units with R290 refrigerant into a receptacle that is a minimum of 14" (36cm) above the floor.
- All electrical work, including wire routing and grounding, must conform to local, state and national electrical codes.
- The equipment must be grounded.
- A separate fuse/circuit breaker must be provided for each unit.
- Check all green ground screws, cables and wire connections to verify they are tight before start-up.
- The maximum allowable voltage variation is ±10% of the rated voltage at equipment start-up (when the electrical load is highest).

Ground Fault Circuit Interrupter

Ground Fault Circuit Interrupter (GFCI/GFI) protection is a system that shuts down the electric circuit (opens it) when it senses an unexpected loss of power, presumably to ground. Manitowoc does not recommend the use of GFCI/GFI circuit protection to energize our equipment. If code requires the use of a GFCI/GFI then you must follow the local code. The circuit must be dedicated, sized properly and there must be a panel GFCI/GFI breaker. We do not recommend the use of GFCI/GFI outlets to energize our equipment as they are known for more intermittent nuisance trips than panel breakers.

Rated Amperages, Horsepower, Voltage & Power Cord Chart

Maximum 10ft (3m) cord with plug.

		Models	Amps	HP	V, Hz, Ph	NEMA Plug
Refrigerators	1 Section	6025XL-S(H)	4.2	0.22	120/60/1	5-15p
		6025XL-G(H)				
	2 Section	6051XL-S(H)	6.0	0.33	120/60/1	5-15p
		6051XL-G(H)				
Freezers	1 Section	6125XL-S(H)	5.5	0.55	120/60/1	5-15p
	2 Section	6151XL-S(H)	10.0	0.68	120/60/1	5-15p

Energy Use For Energy Star® Certified Units

		Models	Energy Use in kWh
Refrigerators	1 Section	6025XL-S	1.18
		6025XL-SH	1.32
		6025XL-G	1.6
		6025XL-GH	1.7
	2 Section	6051XL-S	1.91
		6051XL-G	2.63
		6051XL-SH	2.3
Freezers	1 Section	6125XL-S	4.04
		6125XL-SH	4.13
	2 Section	6151XL-S	7.74
		6151XL-S(H)	7.6

Refrigeration

		Model	BTU/Hour Capacity	Heat of Rejection (BTU)	R290 Charge
1 Section Refrigerators					
Solid	Full Height Doors	6025XL-S	1754	385	113g
	Half Height Doors	6025XL-SH	1754	444	113g
Glass	Full Height Doors	6025XL-G	1754	385	113g
	Half Height Doors	6025XL-GH	1754	444	113g
2 Section Refrigerators					
Solid	Full Height Doors	6051XL-S	2167	697	113g
	Half Height Doors	6051XL-SH	2167	826	113g
Glass	Full Height Doors	6051XL-G	2167	697	113g
	Half Height Doors	6051XL-GH	2167	826	113g
1 Section Freezers					
Solid	Full Height Doors	6125XL-S	1813	858	100g
	Half Height Doors	6125XL-SH	1813	957	100g
2 Section Freezers					
Solid	Full Height Doors	6151XL-S	2574	1416	93g
	Half Height Doors	6151XL-SH	2574	1631	93g

Leveling

After the cabinet has been placed in the desired location, cabinets with legs must be leveled. Level units from front to back and from side to side. Leveling will insure proper door operation and removal of condensate. Cabinets with casters must have the caster brake set so the cabinet cannot move. Glass door models are only supplied on legs.

Stabilizing

It is very important that all legs are properly adjusted to keep the cabinet level, evenly distribute the weight and to make sure the unit will not rock, lean or be unstable.

Leg & Caster Installation

⚠ DANGER

Legs or casters must be installed and the legs or casters must be screwed in completely to prevent bending. When casters are installed the mass of this unit will allow it to move uncontrolled on an inclined surface. These units must be tethered/secured to comply with all applicable codes.

⚠ Warning

The unit must be installed in a stable condition with the front wheels locked. Locking the front casters after installation is the owner's and operator's responsibility.

⚠ Warning

Single Section models with glass doors or drawers are supplied with flanged feet that must be fastened to the floor to prevent the unit from tipping when the door/drawer(s) are opened.

⚠ Warning

Use a jack to lift the refrigeration unit off the ground just far enough to remove the leg/caster. Place blocking underneath the unit. Do not work underneath a raised unit without proper blocking. Do not lift the unit more than necessary to remove the leg/caster. Lifting the unit too far can make the unit unstable.

⚠ Caution

All single-section units require that the swivel casters be mounted on the front and rigid casters be mounted on the rear.

⚠ Caution

Casters are not allowed on glass door single section 6000 due to tip hazard. Casters cannot be order on the unit from the factory or added in the field.

To install the legs or casters:

1. Remove unit from skid.
NOTE: The bolts used to hold the unit to the skid should be re-used as the fourth hex head bolt for each caster or leg plate installation. The bolt should not measure over 2" (5cm) in length.
2. Raise unit to access leg/caster mounting holes on bottom of unit.
3. Attach the legs or casters to bottom of cabinet using hex head bolts.

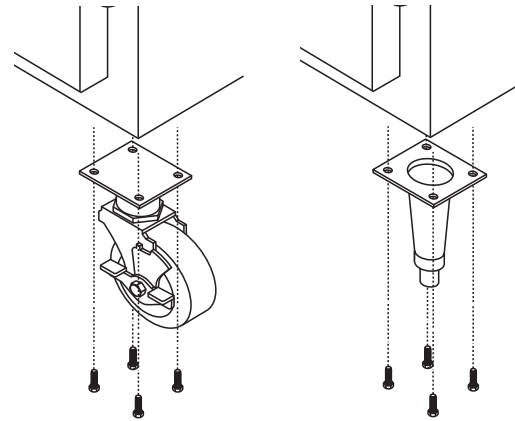

Door Reversal Procedure

To remove the door and unit hinges

1. Remove the front shroud off the unit.
2. Open the door 90° and lift up and off of the frame hinges.
3. Remove the metal screw covers on each of the frame hinges to reveal the bracket screws.
4. Remove all three screws on each of the frame hinge brackets. Keep each assembly and screws to complete hinge orientation process.
5. Remove the nylon hinge cam at the bottom of the frame hinge and reinstall each cam flipped over to change door swing path.
6. Plug exposed holes with acquired plastic plugs. *Part number 9321571.*

To remove the locking bracket

1. With the door off (or open), remove the 2 screws on the inner side of the locking bracket and remove the hook assembly of the locking bracket. This will expose 2 screws fastening the bracket to the cabinet.
2. Remove the now exposed screws to remove the bracket from the cabinet. Keep all assembly and screws to complete the lock reorientation process.
3. Plug exposed holes with acquired plastic plugs. *Part number 9321571.*

To mark and drill new hinge locations follow the steps below and refer to the drawings on page 14.

Note: *Each of these steps are for different size units. You may only need to follow one.*

Note: *Always measure and confirm each location of the etched mark with the opposite side of the cabinet hole locations before drilling.*

Note: *There are no heater wires or other electrical components located near or behind the mounting locations.*

For a **single section full door**, the unit will have laser etched markings on the opposite side of the cabinet face for each of the frame hinge bracket holes and lock bracket holes.

- Drill laser etched markings with a 3/16" drill bit for each of the (3) frame hinge bracket holes and a 5/32" drill bit for the (2) lock bracket holes.

For **single section half door**, the unit cabinet will have *some* of the frame hinge locations etched on the opposite side of the cabinet face. The upper frame hinge of the upper door and the lower frame hinge of the lower door will have etched markings. The other frame hinges and lock locations will need to be measured and reflected from the opposite side of the unit face

- Drill laser etched markings with a 3/16" drill bit for each of the (3) frame hinge bracket holes and a 5/32" drill bit for the (2) lock bracket holes.

For a **two section full door**, the center vertical mullions will not have etchings for frame hinge brackets or locks, these will need to be measured and marked before drilling.

- Drill measured markings with a 3/16" drill bit for each of the (3) hinge bracket holes and a 5/32" drill bit for the (2) lock bracket holes.

For a **two section half door**, the center vertical mullions will not have etchings on the mullion for hinge brackets or locks, these will need to be measured and marked before drilling.

- Drill measured markings with a 3/16" drill bit for each of the (3) hinge bracket holes and a 5/32" drill bit for the (2) lock bracket holes.

To adjust edge mounted door hinge orientation.

1. Remove the vanity cover on each on the edge mounted door hinges.
2. Loosen the middle screw and remove the upper and lower screws.
3. Rotate each of the edge mounted door hinges 180°.
4. Firmly fasten each screw and replace cover.

To install doors in new orientation for both full and two door sections. Repeat the following steps for each applicable door.

1. Using original hardware, firmly mount both the upper and lower hinge brackets to the unit in their new location.
2. Set the door vertically down onto the each of the frame hinges mounted onto the unit.
3. Ensure all doors are plum and aligned with equal gaps. If the door need adjustment; loosen the mount screws, adjust door and retighten mounting hardware.
4. Remove the door and reinstall all the vanity covers on the brackets.
5. Reinstall the door (following step 2).
6. Replace upper shroud on the unit.

To install lock brackets in new orientation. Repeat the following steps for each applicable lock.

1. Using original hardware, firmly mount the lock bracket to the new lock position using the original two screws.
2. Install the lock hook with it's original two screws.

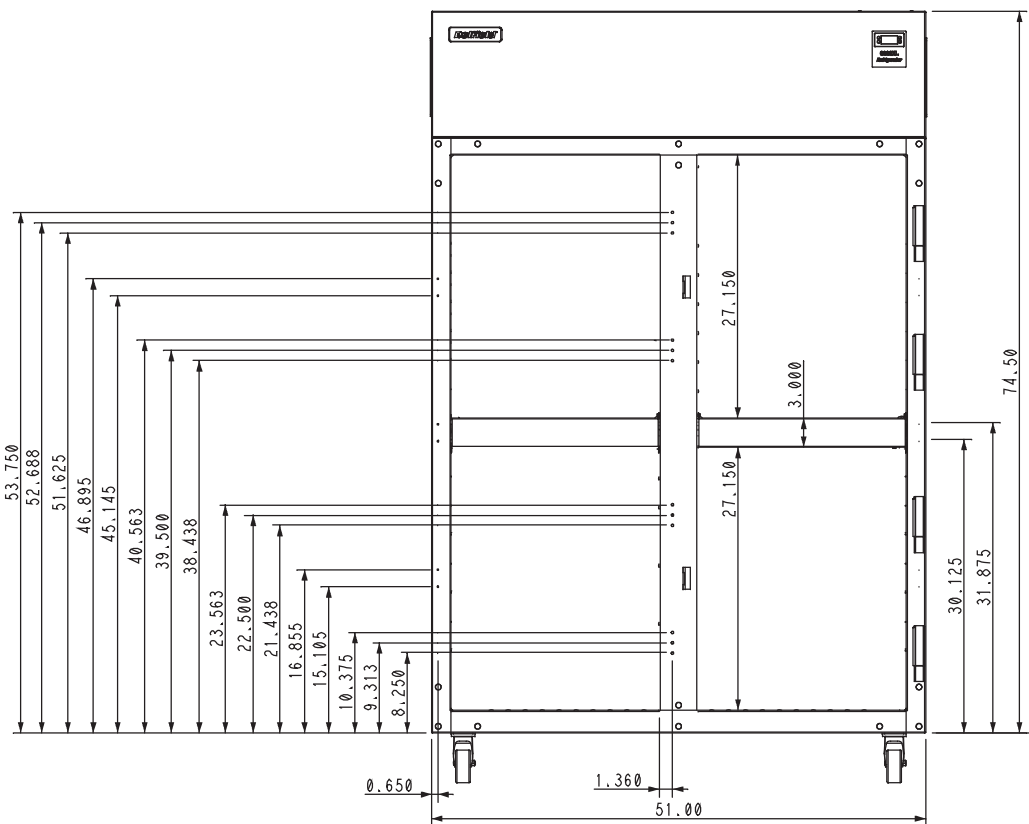
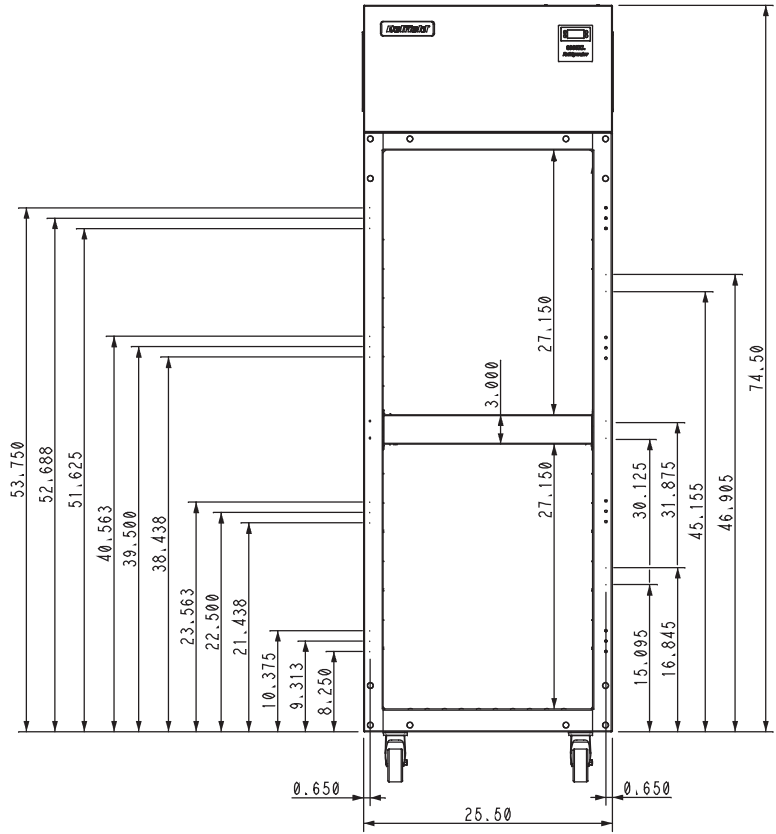
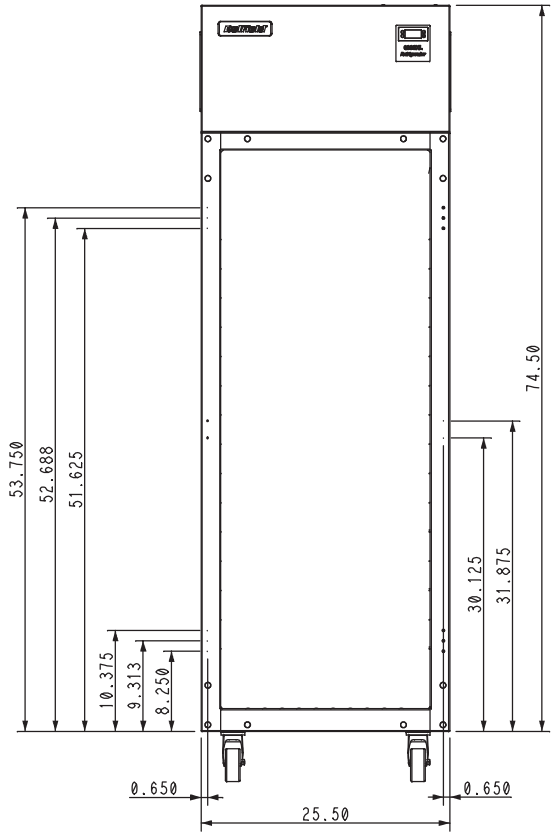

Section 3 Operation

DANGER

Do not operate any appliance with a damaged cord or plug. All repairs must be performed by a qualified service company.

DANGER

Never stand on the unit! They are not designed to hold the weight of an adult, and may collapse or tip if misused in this manner.

Warning

Do not contact moving parts.

Warning

All covers and access panels must be in place and properly secured, before operating this equipment.

Warning

Do not use electrical appliances inside the food storage compartment of this appliance.

Warning

The operator of this equipment is solely responsible for ensuring safe holding temperature levels for all food items. Failure to do so could result in unsafe food products for customers.

Warning

Overloading shelves can damage equipment or cause bodily injury.

Warning

Damp or wet hands may stick to cold surfaces.

Warning

Do not block the supply and return air grills or the air space around the air grills. Keep plastic wrappings, paper, labels, etc. from being airborne and lodging in the grills. Failure to keep the air grills clear will result in unsatisfactory operation of the system.

Caution

Do not throw items into the storage area. Failure to heed this recommendation could result in damage to the interior of the cabinet or to the blower coil.

R290 Controls/Programming/Settings

R290 Refrigerator

Refrigerators are factory set at mid-range to maintain about 38°F (3°C) box temperature.

1. At initial start-up or anytime power is disconnected, then reconnected to the unit, the control will go into defrost mode.
2. The control will enter a DEFROST mode and the display will read dEF. The compressor and condenser fan as well as the evaporator fan will remain off until this initial defrost is complete. This initial defrost cycle may take up to 35 minutes to complete.
3. The display will continue to read dEF for an additional 30 minutes while the cooling cycle cools the box to the set temperature.
4. Then the digital thermostat will display box temperature.
5. The temperature control will cycle the compressor, evaporator fan motor and condenser fan motor to maintain box temperature at the control setting. For more information see R290 Evaporator Fan Operation on page 17.

R290 Refrigerator Defrost

The temperature control also monitors the evaporator temperature and will turn off the compressor and condenser fan motor when needed to allow accumulated frost on the evaporator to clear. During this defrost cycle, the digital temperature display will read dEF. After the defrost cycle is complete, the temperature control will return to a normal cooling cycle, but the display will continue to read dEF until the evaporator returns to normal cooling temperatures (up to 30 minutes).

R290 Freezer

Freezers are factory set at mid-range to maintain about -2°F (-19°C) box temperature.

1. At initial start-up or anytime power is disconnected, then reconnected to the unit, the control will go into defrost mode
2. The control will enter a DEFROST mode and the display will read dEF. The compressor and condenser fan as well as the evaporator fan will remain off until this initial defrost is complete. This initial defrost cycle may take up to 35 minutes to complete.
3. The display will continue to read dEF for an additional 30 minutes while the freezing cycle cools the box to the set temperature.
4. Then the thermostat will display box temperature.
5. The temperature control will cycle the compressor, evaporator fan motor and condenser fan motor to maintain box temperature at the control setting. For more information see R290 Evaporator Fan Operation on page 17.

R290 Freezer Automatic Defrost

The control also monitors compressor total running time and will enter a defrost cycle after total compressor running time is greater than seven hours since the last defrost cycle OR if evaporator coil temperature drops below -30°F (-34°C) (indicating excessive frost on the coil).

R290 Freezer Manual Defrost

If a manual defrost is desired, hold the upper left button for five seconds or unplug the unit for several seconds, then plug unit back in. This will cause the control to re-initialize and then enter a defrost cycle.

When the control enters the defrost mode, it switches off the evaporator fan motor, compressor and condenser fan motor, and switches on the defrost heater to warm the evaporator coil. Thereby melting all frost accumulated during the previous refrigeration cycle. The digital temperature display will now read dEF. The control will continue the defrost cycle for a MINIMUM of six minutes and a MAXIMUM of 35 minutes depending on the amount of frost accumulated on the evaporator coil.

After the defrost cycle is complete, the control returns to a normal refrigeration cycle, however the evaporator fan motor will not switch on until the evaporator reaches -5°F (-21°C) or two minutes AFTER the compressor and condenser fan motor have begun operating. The digital temperature display will continue to read dEF until the evaporator has returned to normal freezing temperatures (up to 30 minutes).

CONTROL & DISPLAY

R290 TEMPERATURE CONTROL & DISPLAY



Control Display

Operation / Indication			
Status	Displayed	🔊	Comments
Normal (°C)	Temp. [°C]		Unit depends on setting (parameters in control)
Normal (°F)	Temp. [°F]		
Show set-point	Temp.		
Set to Defrost	dEF / Temp		Depends on setting (parameters in control or as chosen by upper left button)
Sensor 1 defect	E01 🚨	X	Air sensor
Sensor 2 defect	E02 🚨	X	Coil sensor
Sensor 3 defect	E03 🚨	X	Open
Sensor 4 defect	E04 🚨	X	Open
High temperature alarm	Hi 🚨	X	Automatically switching at 2 sec rate
Low temperature alarm	Lo 🚨	X	
Line voltage too high, above 140 volts	uHi 🚨	X	
Line voltage too low, below 96 volts	uLi 🚨	X	
Control calls for cooling for more than 24 hours straight	LEA 🚨	X	Time includes defrost. Error will go away if the control cycles off the compressor or if the power is shut off. If error is on a cold pan it could be related to a high ambient temperature or not shutting the rail off nightly.

🚨 All alarms sound for approximately 10 seconds and then are silent for 50 seconds. It will do that for 15 cycles and then remain silent. The alarm code will still be present on the display until the fault clears.

R290 Temperature Control & Display Operation

Press upper or lower right button.

- Display show actual set-point (blinking).
 - » If buttons untouched for 3 seconds returns to normal.
- Increase set-point by pressing upper button. Max value depends on parameters in control.
- Decrease set-point by pressing lower button. Min value depends on parameters in control.
 - » If buttons untouched for 3 seconds returns to normal and stores new set-point.

Press upper left button for 5 seconds.

- Start defrost.

Press lower left button for 5 seconds.

- Unit goes into stand-by mode.
 - » The display will read off, then a period.
- Press the lower left button again for 5 seconds.
 - » The display will read on.
 - » The unit will then start up in the defrost mode, and display will read dEF.

R290 Power Switch

All freezers and refrigerators are equipped with a power disconnect switch located behind the louvered end panel. Switch must be in the on position for the unit to operate. If the switch is turned off, then returned to the on position, the unit will enter a defrost cycle and the display will read dEF.

R290 Energy Switch

Refrigerators and freezers are equipped with an energy saver switch for service use. It is located in the electrical box behind the front shroud. It controls the length of time that heat is applied to the door perimeter. If excessive condensation is observed on the door opening, switch to the off position with the help of an authorized service agent. The off position will increase the length of time the door heater is on.

Refrigerator operation - Energy Switch is "ON", signaling Energy Mode active, thus using the least energy. Unit ships from factory in this mode where heaters are deactivated. If the Energy Switch is turned "OFF", the heaters will cycle with the compressor, using more energy.

Freezer operation - Energy Switch is "ON", signaling Energy Mode active, thus using the least energy. Unit ships from factory in this mode where heaters will cycle with the compressor. If the Energy Switch is turned "OFF" by Service in the field, the heaters will be always energized, using more energy.

R290 Temperature Alarm

The alarm will sound and flash "HI" or "LO" 90 minutes after the unit has reached its alarm temperature point or after any power interruption if the temperature is above or below the alarm set points. Refrigerators are factory set at mid-range to maintain about 38°F (3°C) box temperature. The high refrigerator temperature point is 50°F (10°C). The low refrigerator temperature point is 25°F (-4°C). Freezers are factory set at mid-range to maintain about -2°F (-19°C) box temperature. The high freezer temperature point is 20°F (-7°C). Freezers do not have a low temperature point.

R290 EVAPORATOR FAN OPERATION

Depending on the units requirements, units may have evaporator fans that run continually or cycle on and off when power is applied. If you have a unit that you notice the fan is cycling, please see the operations sequence below.

During normal operation the evaporator fan may cycle and/or pulse independently of the compressor. Consult Technical Support at 1-844-724-CARE if you are unsure of the proper function.

	Cooling Cycle				Defrost Cycle	
	Compressor On		Compressor Off		Compressor Off	
	Evap Fan On	Evap Fan Off	Evap Fan On	Evap Fan Off	Evap Fan On	Evap Fan Off
Refrigerator	X		Cycles On 2-Min, Off 2-Min		X	
Freezer	X			X		X

R290 CHANGING DISPLAY FROM FAHRENHEIT TO CELSIUS ON ERC112 CONTROL

1. Simultaneously hold the up and down arrows for 5 seconds to access menu for password protected parameters.



2. Screen should temporarily flash **PAS** and then move to a numeric screen.



3. Scroll to **187** using the up/down arrows and push the stand-by button (lower left button) to enter.



4. Scroll to **dis** using the up/down arrows and push the stand-by button (lower left button) to enter into the display menu.



5. Scroll to **CFu** using the up/down arrows and push the stand-by button (lower left button) to enter the display unit menu.



6. **-F** should be displayed indicating Fahrenheit. Use the down arrow to change it to **-C** for Celsius and hit the stand-by button (lower left button) to enter the change.

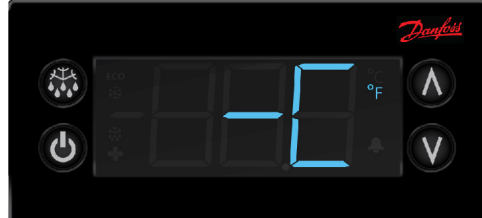

7. Push the defrost button (upper left button) to move out of the display unit menu.



8. Push the defrost button (upper left button) to move out of the display menu and back to the normal display.

NOTE: For steps 7 and 8, display will return back to normal display after 30 seconds of inactivity.



Section 4 Maintenance

⚠ DANGER

It is the responsibility of the equipment owner to perform a Personal Protective Equipment Hazard Assessment to ensure adequate protection during maintenance procedures.

⚠ DANGER

Failure to disconnect the power at the main power supply disconnect could result in serious injury or death. The power switch DOES NOT disconnect all incoming power.

⚠ DANGER

Disconnect electric power at the main power disconnect for all equipment being serviced. Observe correct polarity of incoming line voltage. Incorrect polarity can lead to erratic operation.

⚠ Warning

Never use sharp objects or tools to remove ice or frost. Do not use mechanical devices or other means to accelerate the defrosting process.

Cleaning and Sanitizing Procedures

⚠ Caution

Maintenance and servicing work other than cleaning as described in this manual must be done by an authorized service personnel.

GENERAL

⚠ Warning

When using cleaning fluids or chemicals, rubber gloves and eye protection (and/or face shield) must be worn.

You are responsible for maintaining the equipment in accordance with the instructions in this manual. Maintenance procedures are not covered by the warranty.

Maintenance	Daily	Weekly	Monthly	After Prolonged Shutdown	At Start-Up
Interior	X			X	X
Gasket	X			X	X
Exterior	X			X	X
Drain		X		X	X
Condenser Coil			X	X	X
Casters			X	X	X

INTERIOR CLEANING**Notice**

When cleaning interior and exterior of unit, care should be taken to avoid the front power switch and the rear power cord. Keep water and/or cleaning solutions away from these parts.

Notice

Never use a high-pressure water jet for cleaning or hose down or flood interior or exterior of units with water. Do not use power cleaning equipment, steel wool, scrapers or wire brushes on stainless steel or painted surfaces.

The interior can be cleaned using soap and warm water. If this isn't sufficient, try ammonia and water or a nonabrasive liquid cleaner.

EXTERIOR CLEANING**Notice**

Never use an acid based cleaning solution on exterior panels! Many food products have an acidic content, which can deteriorate the finish. Be sure to clean the stainless steel surfaces of ALL food products.

Clean the area around the unit as often as necessary to maintain cleanliness and efficient operation.

Wipe gasket and surfaces with a damp cloth rinsed in water to remove dust and dirt from the outside of the unit. Always rub with the "grain" of the stainless steel to avoid marring the finish. If a greasy residue persists, use a damp cloth rinsed in a mild dish soap and water solution. Wipe dry with a clean, soft cloth.

Never use steel wool or abrasive pads for cleaning. Never use chlorinated, citrus based or abrasive cleaners.

Stainless steel exterior panels have a clear coating that is stain resistant and easy to clean. Products containing abrasives will damage the coating and scratch the panels. Daily cleaning may be followed by an application of stainless steel cleaner which will eliminate water spotting and fingerprints. Early signs of stainless steel breakdown are small pits and cracks. If this has begun, clean thoroughly and start to apply stainless steel cleaners in attempt to restore the steel.

DRAIN

Each unit has a drain located inside the unit that removes the condensation from the evaporator coil and routes it to an external condensate evaporator pan. Each drain can become loose or disconnected during normal use. If you notice water accumulation on the inside of the unit, be sure the drain tube is connected to the evaporator drain pan. If water is collecting underneath the unit, make sure the end of the drain tube is in the condensate evaporator. The leveling of the unit is important as the units are designed to drain properly when level. Be sure all drain lines are free of obstructions.

CLEANING THE CONDENSER COIL

In order to maintain proper refrigeration performance, the condenser fins must be cleaned of dust, dirt and grease regularly. It is recommended that this be done monthly. If conditions are such that the condenser is totally blocked in a month, the frequency of cleaning should be increased. Clean the condenser with a vacuum cleaner or stiff brush. If extremely dirty, a commercially available condenser cleaner may be required.

Failure to maintain a clean condenser coil can initially cause high temperatures and excessive run times. Continuous operation with a dirty or clogged condenser coil can result in compressor failure. Neglecting the condenser coil cleaning procedures will void any warranties associated with the compressor and cost to replace the compressor.

CASTERS

Wipe casters with a damp cloth monthly to prevent corrosion.

DOORS/HINGES

Over time and with heavy-use doors, the hinges may become loose. If this happens, tighten the screws that mount the hinge brackets to the frame of the unit. Loose or sagging doors can cause the hinges to pull out of the frame, which may damage both the doors and the hinges. In some cases this may require qualified service agents or maintenance personnel to perform repairs.

PREVENTING BLOWER COIL CORROSION

To help prevent corrosion of the blower coil, store all acidic items, such as pickles and tomatoes, in seal-able containers. Immediately wipe up all spills.

Section 5 Wiring and Parts

6000XL WIRING

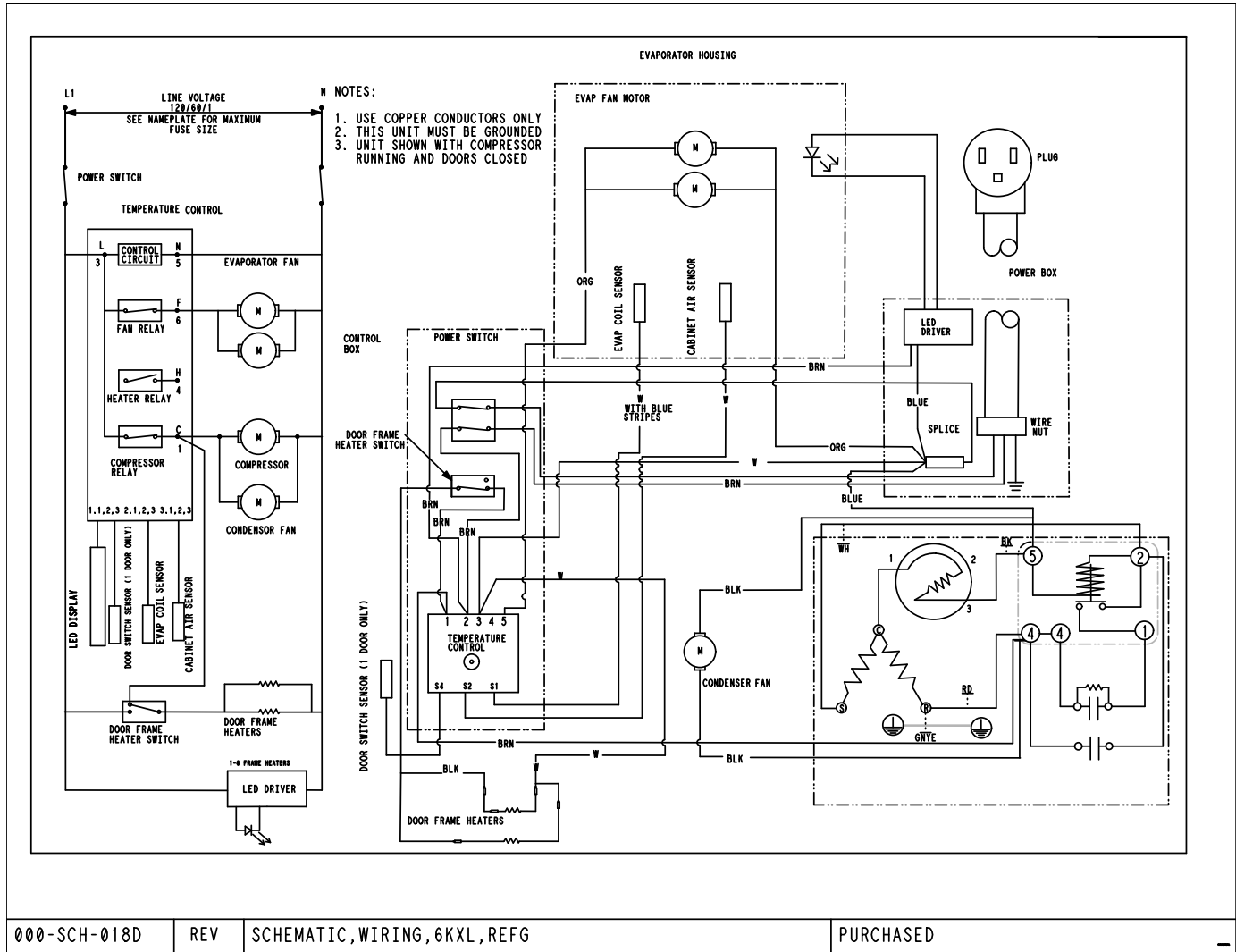



DELFIELD
980 SOUTH ISABELLA ROAD, MOUNT PLEASANT, MI 48858
800-733-8821
WWW.DELFIELD.COM



Welbilt offers fully-integrated kitchen systems and our products are backed by KitchenCare® aftermarket parts and service. Welbilt's portfolio of award-winning brands includes Cleveland™, Convothem®, Crem®, Delfield®, fitkitchen®, Frymaster®, Garland®, Kolpak®, Lincoln®, Manitowoc®, Merco®, Merrychef® and Multiplex®.

Bringing innovation to the table • welbilt.com