

Project _____
Item _____
Quantity _____
CSI Section 11400
Approved _____
Date _____

FlexiShield® Food Shields

Flexible shield, rotating front

Models

- DCFSRF

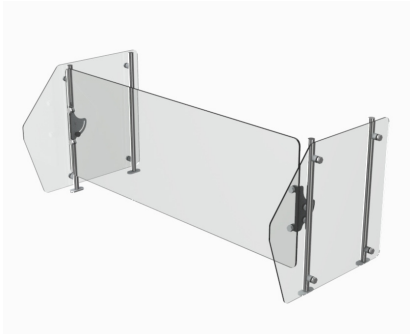

DCFSRF

Standard Features

- Mostly glass display allows you to see product from every angle
- 1" stainless steel legs
- Meets 2014 NSF requirements
- Flange mounted foot makes installation easy
- Comes fully assembled from the factory
- Standard end glass
- One year parts and labor standard warranty
- Angle adjustment between 0 - 87 degrees

Options & Accessories

- Black powder coat
- Ends can be eliminated when used for prepackaged foods

Specifications

1" stainless steel legs and flanged feet are standard. End glass is 1/4" tempered. Front glass is 3/8" tempered. Chrome plated hardware standard.



FlexiShield® Food Shields

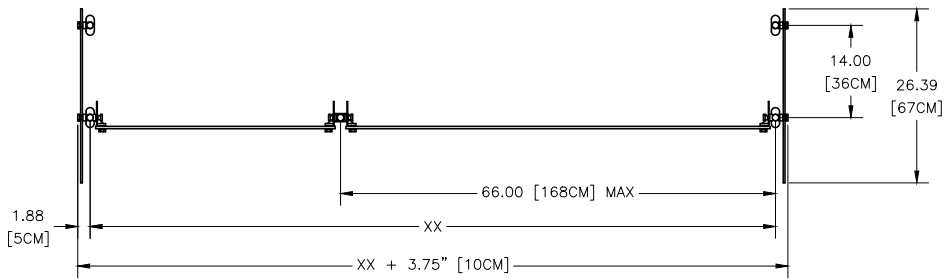
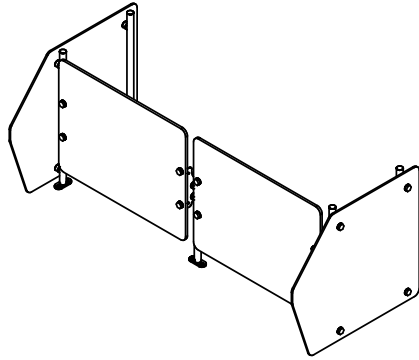

Plan View

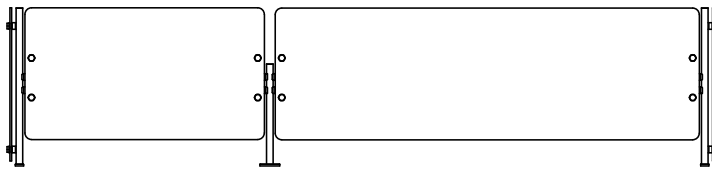

Elevation View

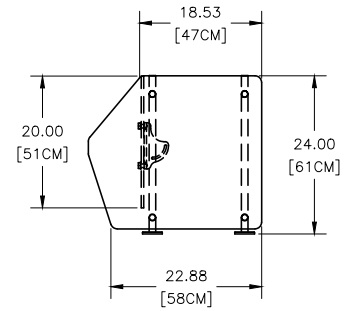

Side View

Specifications				
Model	L	W	H	Ship Weight
DCFSSS	XX	26.39" (67cm)	24.00" (61cm)	Contact factory

Welbilt reserves the right to make changes to the design or specifications without prior notice.