

## FlexiShield® Food Shields

Double Tier, Bottom Tier Sneeze Guard,  
Second Tier Full Glass Front

### Models

- DCFSHG Available in 1" increments up to 120" long

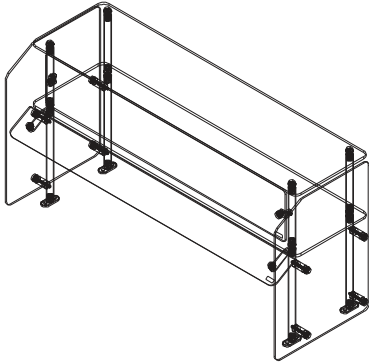

DCFSHG

### Standard Features

- Mostly glass display allows you to see product from every angle
- 1" stainless steel legs
- Meets 2011 NSF requirements
- Flange mounted foot makes installation easy
- Comes fully assembled from the factory
- Standard end glass
- One year parts and labor standard warranty

### Options & Accessories

- Radiant heat lamp\*
- Stainless steel shelf
- Black powder coat
- Fluorescent light\*
- LED lights\*
- Narrow halogen heatlamp\*
- Narrow halogen heatlamp with xenon lights\*
- Narrow xenon display lights\*

\* Inclusion of this option will alter the electrical specifications of the unit

### Specifications

1" stainless steel legs and flanged feet are standard. Models 52.50" (133cm) in length and less will have two sets of legs. Models greater than 52.50" (133cm) in length will have three sets of legs. Top glass is 3/8" tempered. End glass is 1/4" tempered. Front glass is 1/4" tempered. Chrome plated hardware standard.



Models 52.50" (133cm) in length and less will have two sets of legs.  
 Models greater than 52.50" (133cm) in length will have three sets of legs.

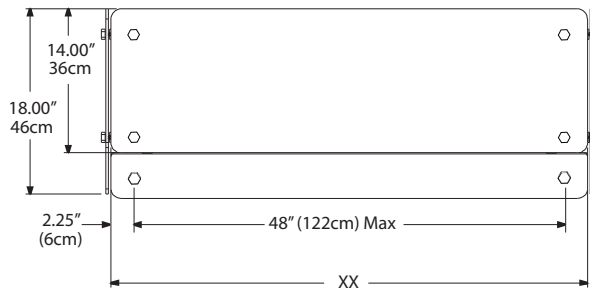
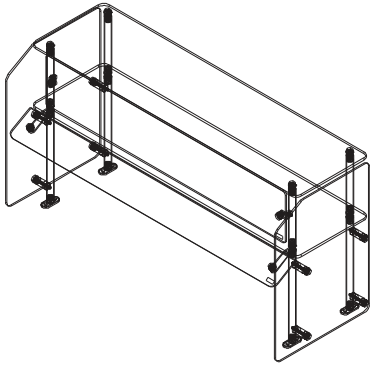

Plan View

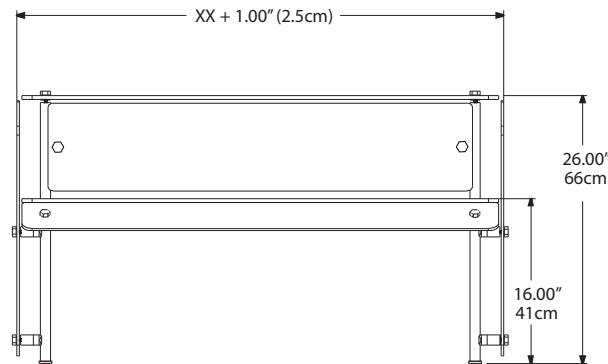

Elevation View

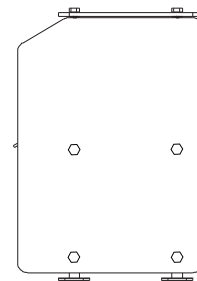

Side View

Specifications				
Model	L	W	H	Ship Weight
DCFSHG	XX	18.00" (46cm)	26.00" (66cm)	Contact factory

Welbilt reserves the right to make changes to the design or specifications without prior notice.

FlexiShield® Food Shields